

FLAT HEAT PIPE / MHP-1220A066A

General Specification

Item		Description
Part Number		MHP-1220A066A
Material of Container		Aluminium 1070
Wick Structure		Groove
Working Fluid		Acetone
Dimension	Thickness	1.2 mm
	Width	20.0 mm
	Length	66.0 mm
Weight		3.8 g (Average)
Qmax	Horizontal	5 W (at 50°C)
	Vertical	18 W (at 50°C)
Typical Thermal Resistance		<0.4°C / W (Average)
Operating Inclination, \emptyset		0 ~ 90°
Operating Temperature		-40 ~ 100°C

Scope

This specification details the requirements and applications for 1.2mm x 20.0mm x 66.0mm.

Dimensions

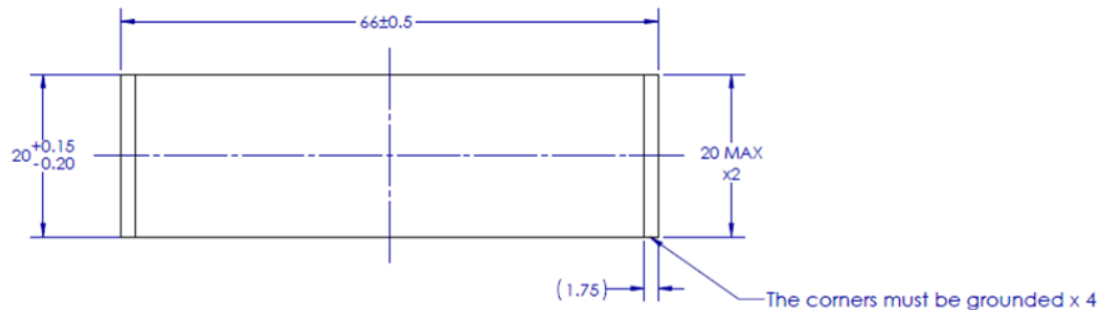

AMEC Thermasol

1-2 Steam Mill Lane, Great Yarmouth, Norfolk, NR31 0HP

Telephone: +44(0) 1493 668622

Email: sales@amecthermasol.co.uk Website: www.amecthermasol.co.uk

FLAT HEAT PIPE / MHP-1220A066A

Performance

The experimental test bench is composed of support that assumes the inclination of MHP. The MHP is electrically heated at a section of length (L_e), and cooled at an opposite section of a length (L_c). K type thermocouples are placed along the MHP to display the temperature variations. To obtain the operating temperature for a MHP, usually a length of L_a insulates a middle section of the tested MHP. Temperatures are measured through a data acquisition (YOKAGAQA DAQSTATION DX2000). Evaporator section has been made of heat block with cartridge heater. The condenser section has been made of water jacket in which cooling water circulates. A cooling bath is used to control the cooling fluid temperature.

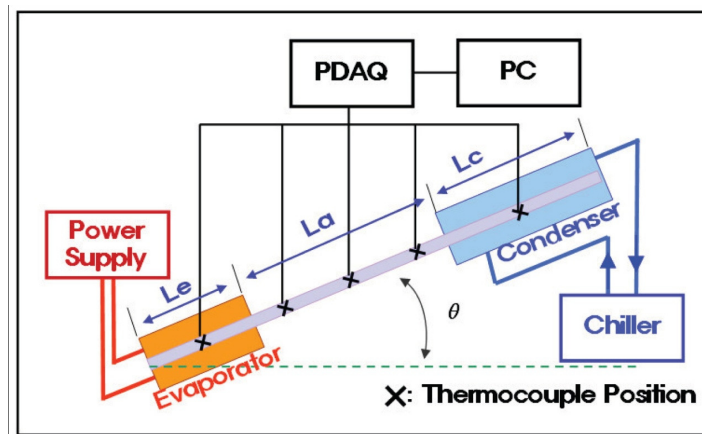

Qmax Test Apparatus

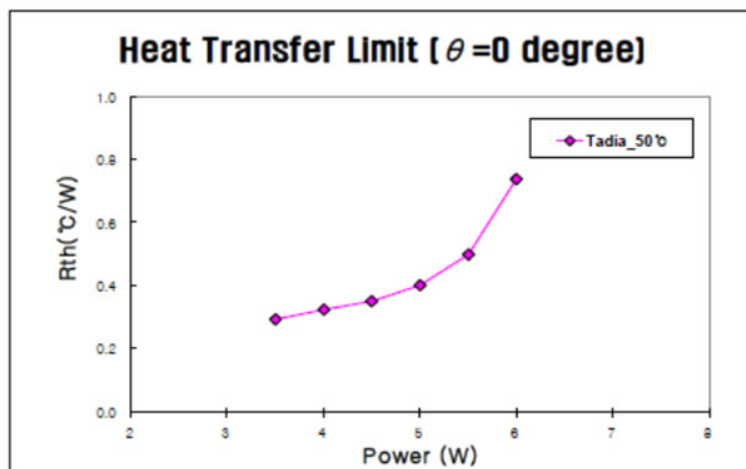

Fig. 3 Maximum Heat Transfer Rate at $\theta=0^\circ$, Tadia=50°C
($L_e=28\text{mm}$, $L_a=30\text{mm}$, $L_c=67\text{mm}$)

AMEC Thermasol

1-2 Steam Mill Lane, Great Yarmouth, Norfolk, NR31 0HP

Telephone: +44(0) 1493 668622

Email: sales@amecthermasol.co.uk Website: www.amecthermasol.co.uk

FLAT HEAT PIPE / MHP-1220A066A

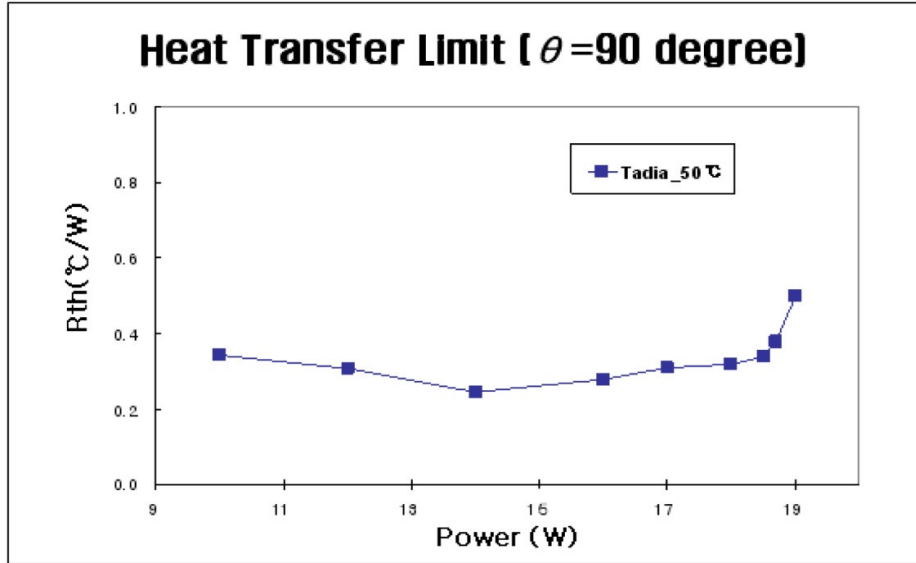

Maximum Heat Transfer Rate at $\theta=90^\circ$, Tadia=50°C
 (Le=28mm, La=30mm, Lc=67mm)

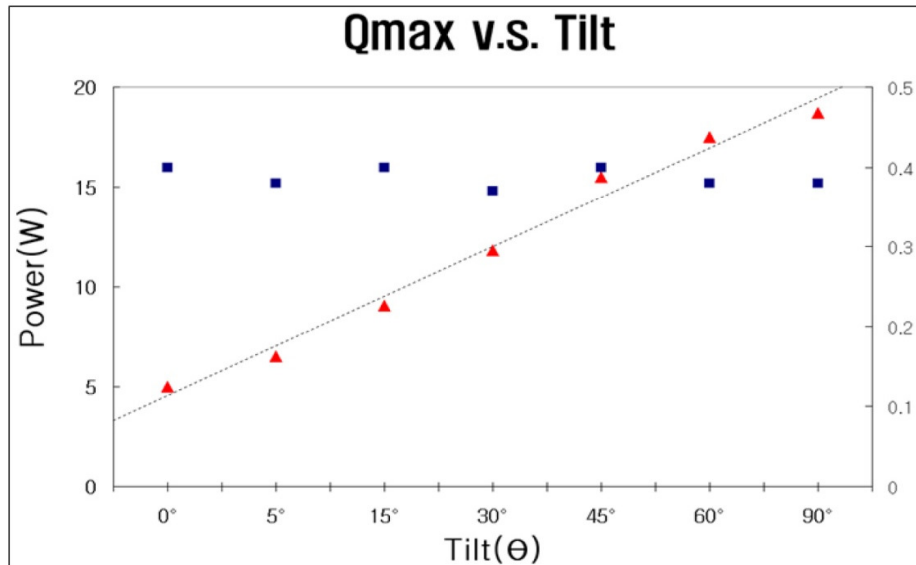

Maximum Heat Transfer Rate vs. Inclination at Tadia=50°C
 (Le=28mm, La=30mm, Lc=67mm)

AMEC Thermasol

1-2 Steam Mill Lane, Great Yarmouth, Norfolk, NR31 0HP

Telephone: +44(0) 1493 668622

Email: sales@amecthermasol.co.uk Website: www.amecthermasol.co.uk

FLAT HEAT PIPE / MHP-1220A066A

High Temperature Leak Test

Every manufactured MHP is sealed with a mechanical pinch system. The mechanical pinch of container results in a cold weld seal. The average leak temperature is about 170°C.

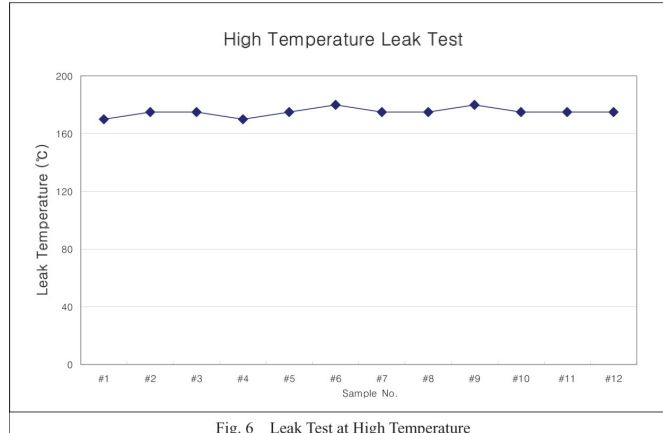

Fig. 6 Leak Test at High Temperature

Thermal Response Test

Every manufactured component must pass the thermal response test to ensure its operation and Vacuum and leakage check. The experimental test bench is schematically shown in Fig.6. Water bath temperature, (**T_w**) is set at 50°C and the temperature of other end, **T_t** is measured immediately after it is placed vertically into the water bath. The criterion for acceptance is 5°C (**T_w** – **T_t**).

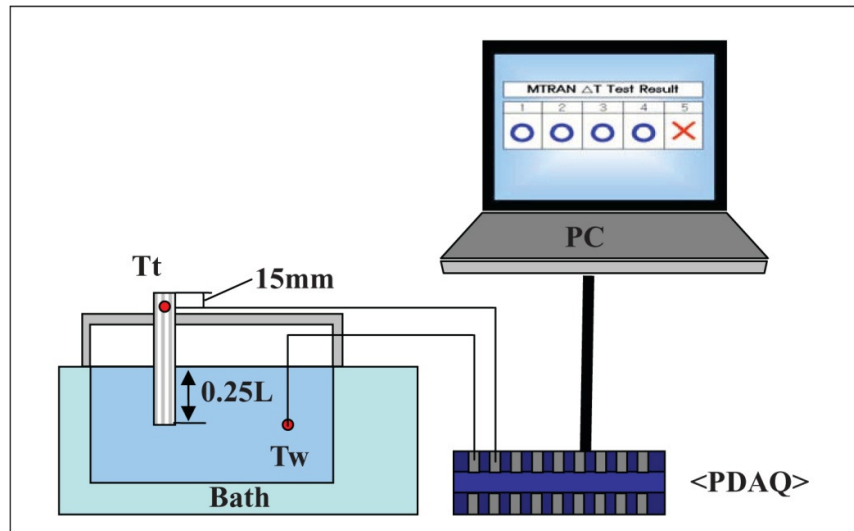

Fig. 7 Thermal Response Test Apparatus

AMEC Thermasol

1-2 Steam Mill Lane, Great Yarmouth, Norfolk, NR31 OHP

Telephone: +44(0) 1493 668622

Email: sales@amecthermasol.co.uk Website: www.amecthermasol.co.uk